

8 7 6 5 4 3 2 1

D  
C  
B  
A

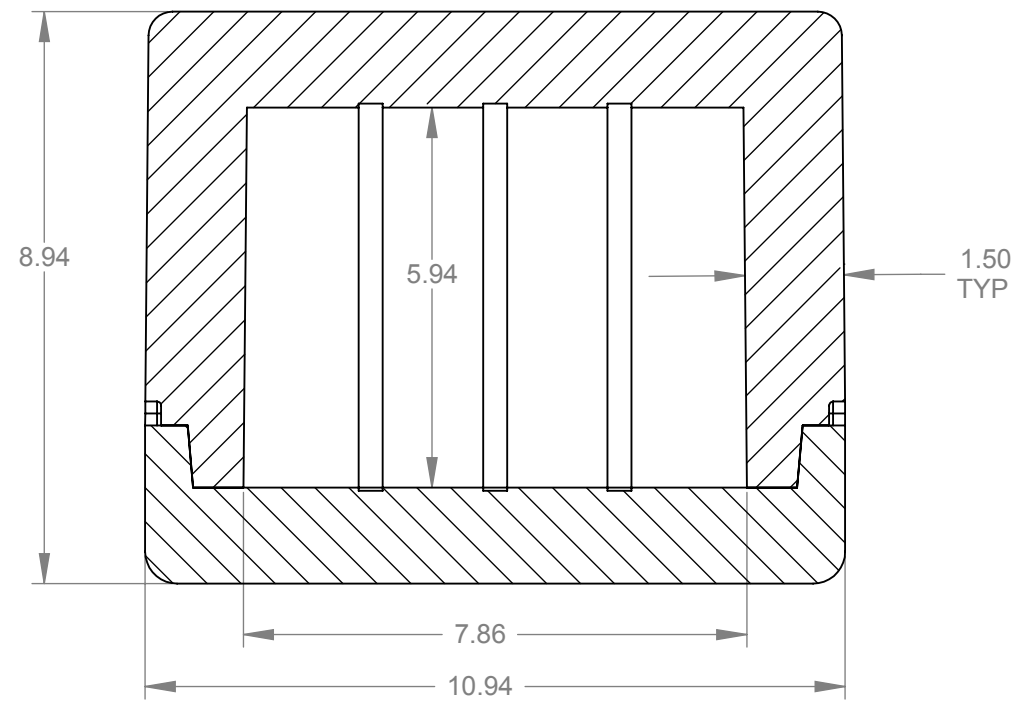

SECTION C-C

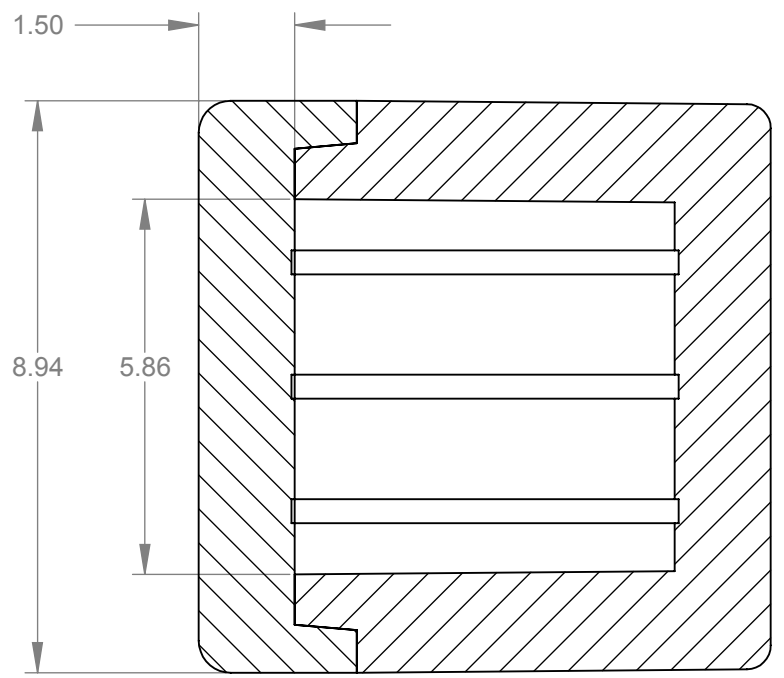
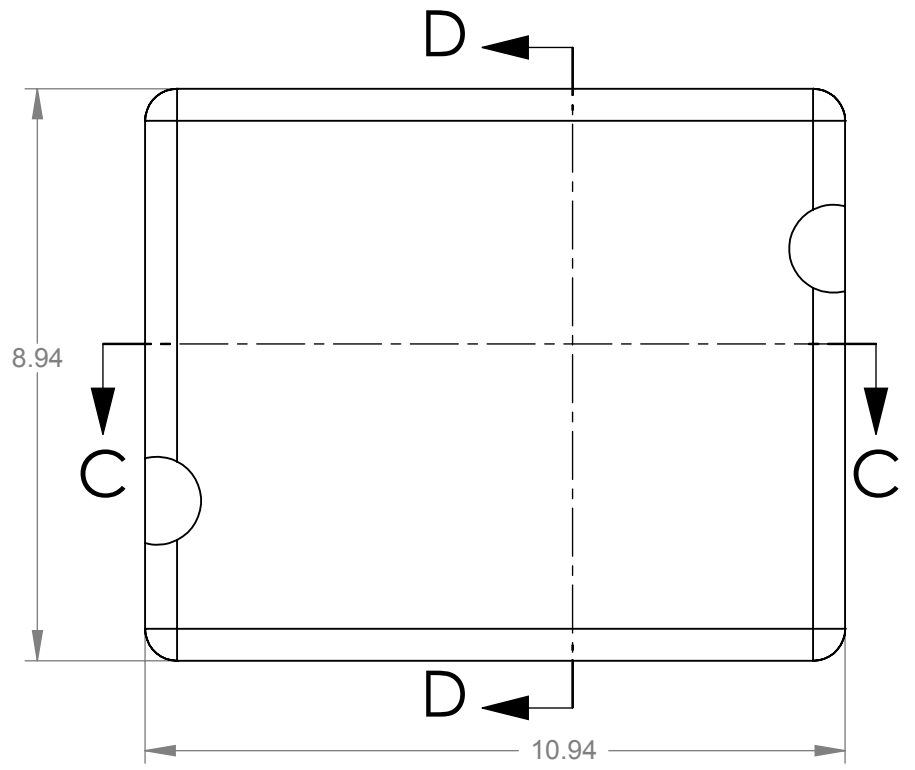

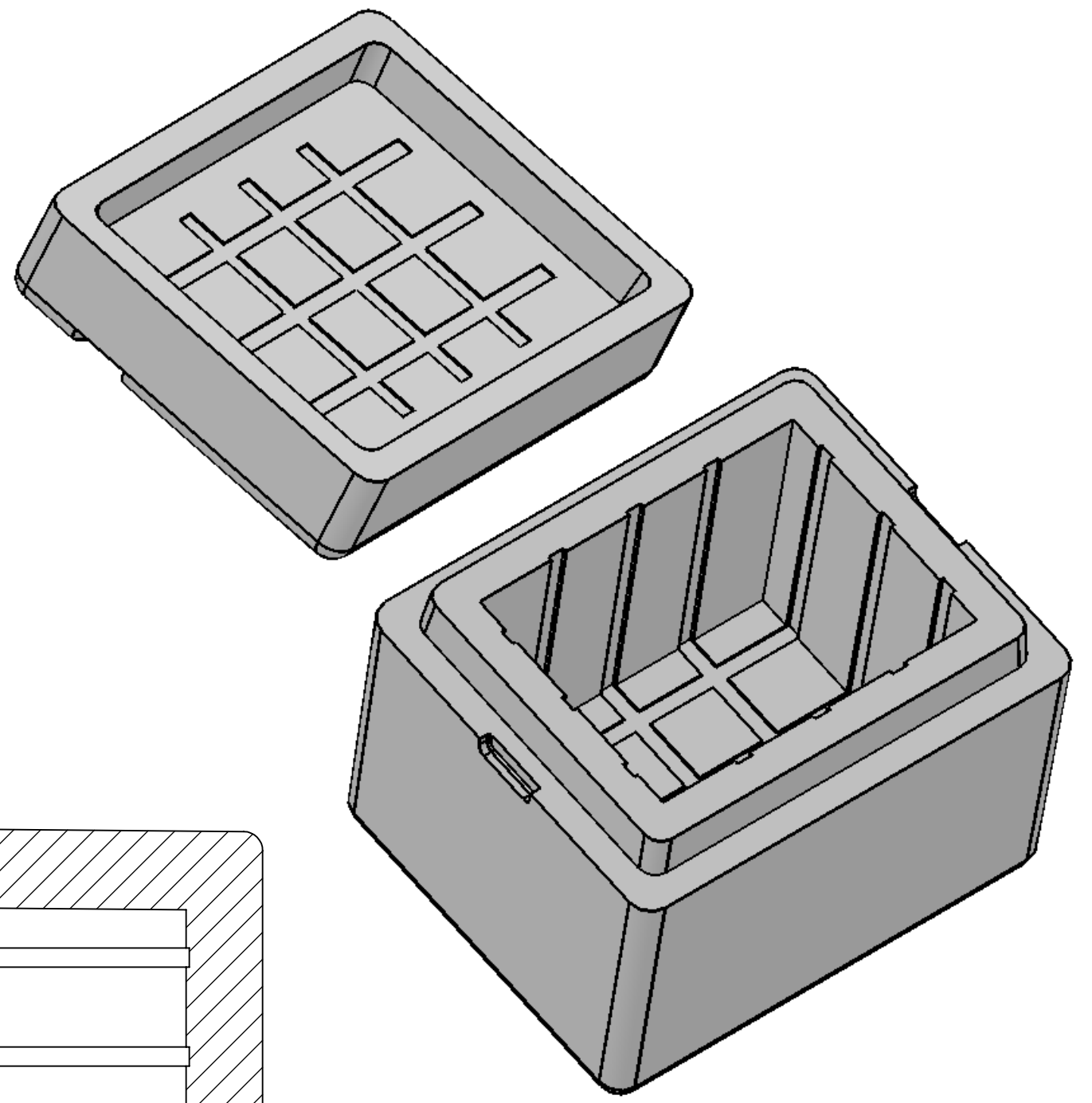

SECTION D-D



STANDARD EPS TOLERANCES FOR DENSITY 1.12 TO 3.0 PCF

DIM. INCH(MM)	TOL. INC(MM)
0.0 - 6.0(152)	+/- .039 (1)
6.0(152) - 12.0 (305)	+/- .06 (1.5)
12.0(305) - 24.0(610)	+/- .098 (2.5)
24.0(610) - 48.0(1220)	+/- .12 (3)
48.0(1220) - GREATER	+/- .20 (5)

<b>PROPRIETARY AND CONFIDENTIAL</b> <small>THE INFORMATION CONTAINED IN THIS DRAWING IS THE SOLE PROPERTY OF marko foam production ANY REPRODUCTION IN PART OR AS A WHOLE WITHOUT THE WRITTEN PERMISSION OF marko foam production IS PROHIBITED.</small> MATERIAL: EPS 1.25 PCF FINISH: DO NOT SCALE DRAWING	DRAWN	NAME	DATE		
	CHECKED				
	ENG APPR.	Ilir Bordoniqi	04/12/10	<b>IC-288</b> <small>SIZE DWG. NO.</small> <b>A</b> CM 1617B - K1014 - 12B CM 1618L - K1014 - 12L	<small>REV.</small>
	MFG APPR.				
	Q.A.				
COMMENTS:			VB - 419 VL - 168	<small>SCALE:1:3</small>	<small>WEIGHT:</small>
				<small>SHEET 1 OF 1</small>	

8 7 6 5 4 3 2 1