

8 7 6 5 4 3 2 1

D
C
B
A

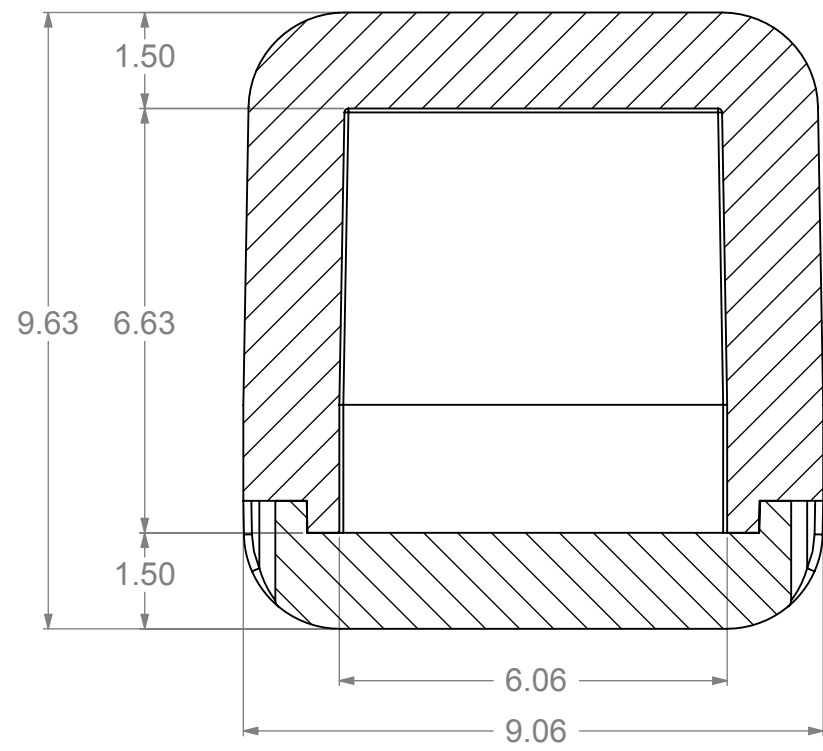

SECTION B-B

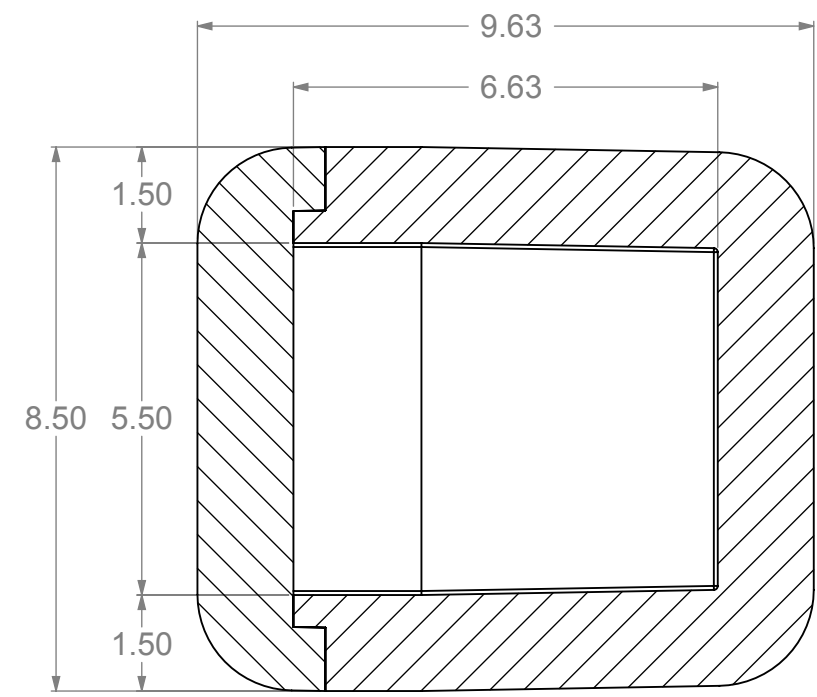
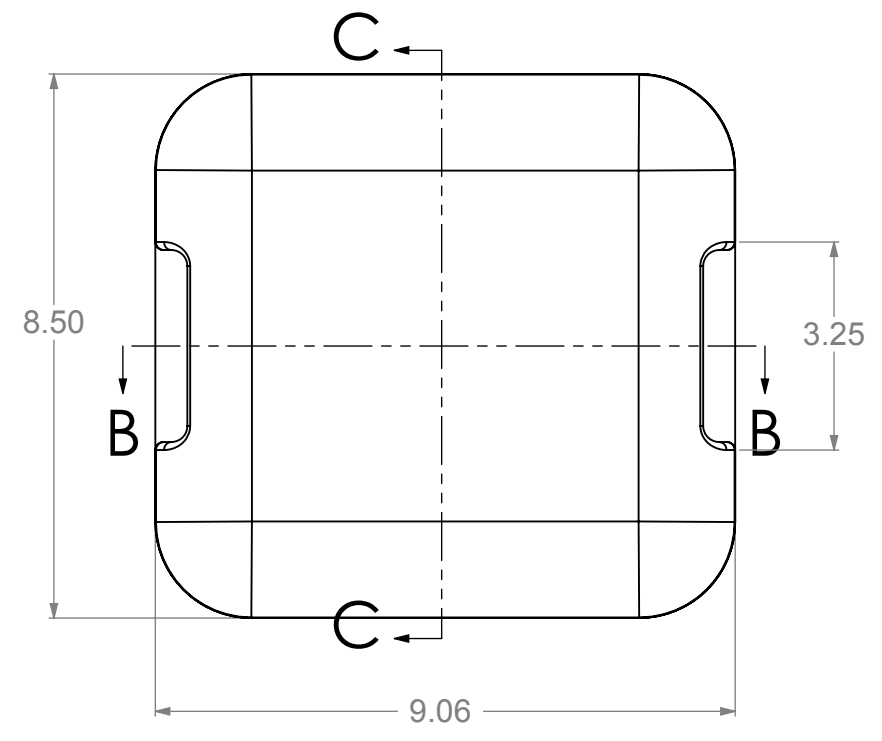

SECTION C-C

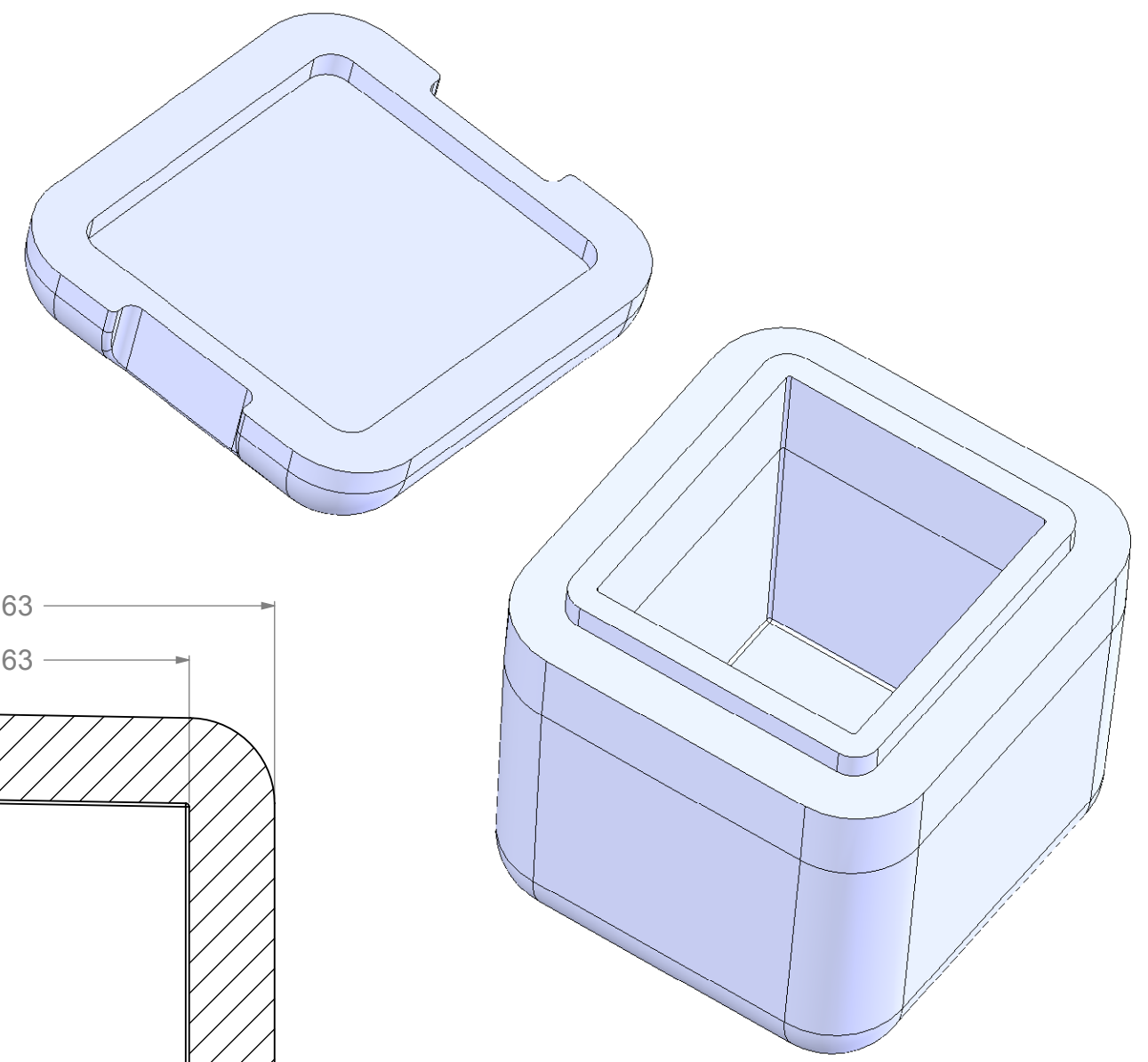

STANDARD EPS TOLERANCES FOR DENSITY 1.12 TO 3.0 PCF

DIM. INCH(MM)	TOL. INC(MM)
0.0 - 6.0(152)	+/- .039 (1)
6.0(152) - 12.0 (305)	+/- .06 (1.5)
12.0(305) - 24.0(610)	+/- .098 (2.5)
24.0(610) - 48.0(1220)	+/- .12 (3)
48.0(1220) - GREATER	+/- .20 (5)

PROPRIETARY AND CONFIDENTIAL THE INFORMATION CONTAINED IN THIS DRAWING IS THE SOLE PROPERTY OF marko foam production. ANY REPRODUCTION IN PART OR AS A WHOLE WITHOUT THE WRITTEN PERMISSION OF marko foam production IS PROHIBITED. MATERIAL: EPS 1.0 PCF FINISH: DO NOT SCALE DRAWING	DRAWN	NAME	DATE
	CHECKED		
	ENG APPR.	Ilir Bordoniqi	04/12/10
	MFG APPR.		
	Q.A.		
COMMENTS:	V _B - 354 V _L - 109		

IC - 217		
SIZE DWG. NO. A CM 5188 - K1317 - 12/6	REV.	SHEET 1 OF 1
SCALE: 1:3	WEIGHT:	SHEET 1 OF 1

8 7 6 5 4 3 2 1