

		REVISIONS			
ZONE	REV.	DESCRIPTION	DATE	APPROVED	

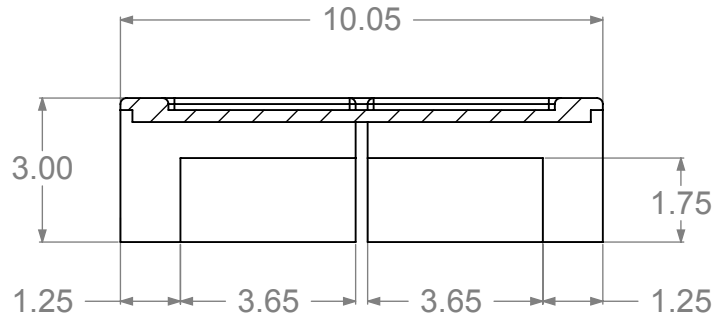

SECTION E-E

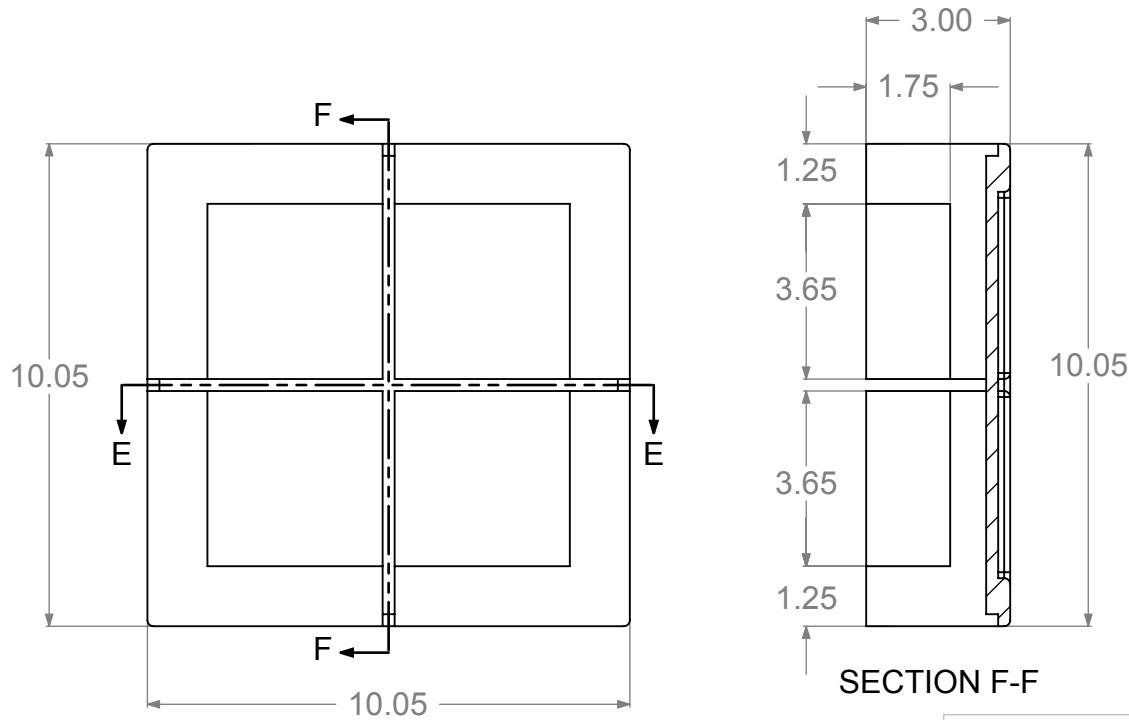
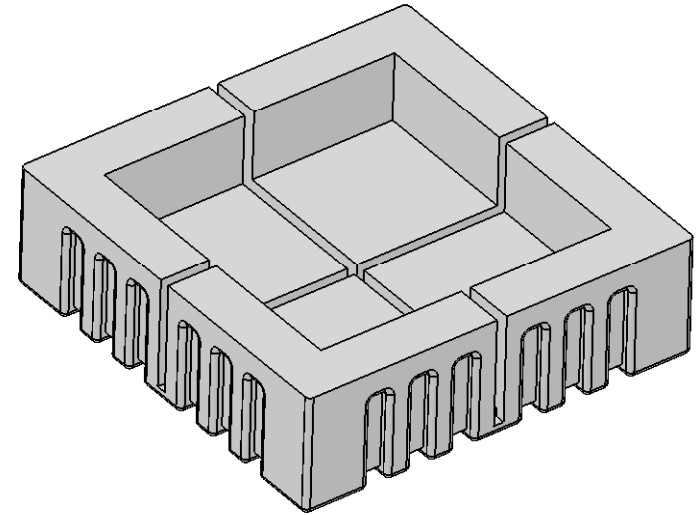

SECTION F-F

STANDARD EPS TOLERANCES  
FOR DENSITY 1.12 TO 3.0 PCF

DIM. INCH(MM)	TOL. INC(MM)
0.0 - 6.0(152)	+/- .039 (1)
6.0(152) - 12.0 (305)	+/- .06 (1.5)
12.0(305) - 24.0(610)	+/- .098 (2.5)
24.0(610) - 48.0(1220)	+/- .12 (3)
48.0(1220) - GREATER	+/- .20 (5)

**PROPRIETARY AND CONFIDENTIAL**

THE INFORMATION CONTAINED  
IN THIS DRAWING IS THE SOLE  
PROPERTY OF marko foam  
production ANY REPRODUCTION  
IN PART OR AS A WHOLE WITHOUT  
THE WRITTEN PERMISSION OF  
marko foam production IS PROHIBITED.

**MATERIAL**

**EPS, EPE,  
CO-POLYMER**

DO NOT SCALE DRAWING

NAME DATE

DRAWN		
CHECKED		
ENG APPR.	Ilir Bordoniqi	09/07/10
MFG APPR.		
Q.A.		

**COMMENTS:**

**V-180**

**marko**  
foam products inc



**CB-102**

SIZE	DWG. NO.	REV.
<b>A</b>	CM1398 - K1014 - 12/48	
SCALE:1:4	WEIGHT:	SHEET 1 OF 1